

SIDE ELEVATION

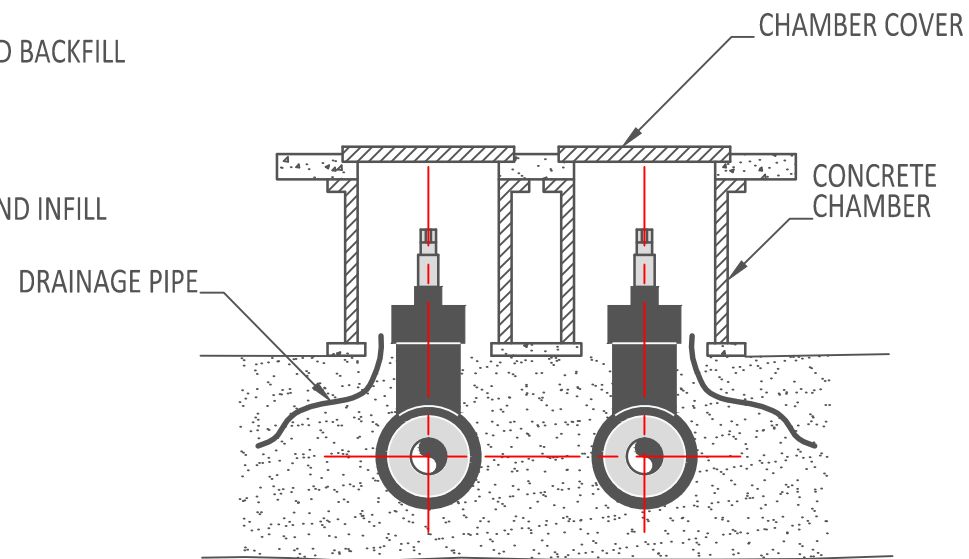

SECTION

\*CHAMBER, CHAMBER COVERS & DRAINAGE PIPES BY CIVIL CONTRACTOR.  
 (THIS DESIGN IS INDICATIVE ONLY. LOADING AND GROUND CONDITIONS  
 TO BE ESTABLISHED BY CIVIL ENGINEERING DESIGNER/ CONTRACTOR).

**durotan**

Pre-insulated pipe systems

DUROTAN LTD, WEST HOUSE, WEST STREET, BUCKINGHAM, MK18 1HE.  
 Tel: 01280 814 048. Fax: 01280 817 842. Email: general@durotan.ltd.uk www.durotan.ltd.uk

PRE-INSULATED PIPE SYSTEM:

**DUROTAN STEEL**

DETAIL NAME:

**DOUBLE ISOLATING VALVE  
 WITH PROVING VALVE**

DRAWING No:

**DS4.4**

DRAWN BY:

C.AUSTEN

DRAWN DATE:

12.11.15

SCALE:

N.T.S

REV:

-